

> RGW

WATER-WATER CHILLERS AND HEAT PUMPS FOR INDOOR INSTALLATION



Unit with closing panels

Available range

Unit type

IR	Chiller
IW	Heat pump (reversible on the water side)
IP	Heat pump (reversible on the refrigerant side)
BR	Chiller Brine
BW	Heat pump Brine (reversible on the water side)
BP	Heat pump Brine (reversible on the refrigerant side)

Version

VB	Base version
----	--------------

Acoustic setting up

AB	Base setting up
AS	Low noise setting up
AX	eXtra low noise setting up

Unit description

This series of water-water chillers and heat pumps satisfies the cooling and heating requirements of commercial and industrial plants of medium size.

All the units are suitable for indoor installation and can be applied to fan coil plants, radiant floor plants and high efficiency radiators plants.

The refrigerant circuit is equipped with 2 scroll compressors, mounted on rubber vibration-damper supports, plant side heat exchanger brazed plate-type in stainless steel (AISI 316), complete with thermal insulation shell and differential pressure switch, source side exchanger brazed plate-type in stainless steel (AISI 316), complete with thermal insulation (IW, IP, BW, BP only) and differential pressure switch. (IP, BP only), thermostatic

expansion valve or electronic expansion valve (standard for IP, BP), 4-way valve, dehydrator filter, refrigerant circuit protected by refrigerant safety valve, low and high pressure switches, electrical panel for power and control complete with main breaker power supply with door lock function microprocessor controller with keyboard-display, and phase sequence controller (standard). When developing the range special attention has been paid to the choice of heat exchangers in order to obtain high efficiencies at full and partial loads to maximise the seasonal efficiency rating (ESEER) and therefore reduce consumption and running costs. The units can be chosen in Basic setting up (AB) (unit without closing panels), Low noise setting up (AS), featuring closing panels coated with acoustic material, Extra Low noise setting up (AX) featuring closing panels coated with superior acoustic material and soundproofing jackets on the compressors.

A wide range of accessories completes the commercial offer. These include pumping modules with 1 or 2 pumps available with standard or high head with a maximum of 4 pumps: 2 on plant side and 2 on source side.

The electronic controller can manage the various condensation control systems of the numerous applications required, enabling the control of 2-way or 3-way modulating valves (also offered as accessories) or the control of pumps under INVERTER. The units can therefore be combined with liquid coolers (dry-coolers), cooling towers, geothermal boreholes or use for water cooling city or well water. All the units are carefully built in compliance with the current regulations and individually tested. Installation therefore only requires the electrical and hydraulic connection.

Options

Pumping Modules

Available on various configurations:

- 1 o 2 pumps plant side
- 1 o 2 pumps source side
- pumps standard, high and extra high pressure head

Expansion valve

- thermostatic
- electronic (standard for IP, BP)

Suitable for outdoor installation

Accessories

Rubber vibration dampers

Remote controller

Serial Interface Modbus-RS 485

Programmer clock

Phase sequence and voltage controller

Low temperature kit

High and low pressure gauges

High temperature thermostat

Compressors shut-off valves

(for IR, BR, IW, BW only)

Outdoor air sensor

Water flow switch

Victaulic hydraulic fittings

Victaulic bends

Victaulic water shut-off valves

Victaulic water filter

2-way valve for cond./evap control

3-way valve for cond./evap control

Compressors start-up with soft starter

Compressors power factor correction

Electrical load protection with thermal magnetic circuit breakers

NET NOMINAL performances - Standard plants - EUROVENT certified data

IR		70.2	80.2	90.2	105.2	120.2	135.2	150.2	170.2	190.2	215.2	240.2	
W30W7	Cooling capacity	69,5	78,5	91,4	104,3	117,2	132,1	146,9	168,8	190,5	214,3	238,1	kW
	Power input	16,4	18,1	21,9	25,2	28,6	32,3	36,3	41,3	46,4	53,0	59,7	kW
	EER	4,23	4,34	4,17	4,14	4,10	4,09	4,05	4,09	4,11	4,04	3,99	W/W
	ESEER	5,22	5,26	5,07	5,04	5,02	5,03	5,05	5,03	5,07	5,03	5,04	W/W
	Water flow rate plant side	3,3	3,8	4,4	5,0	5,6	6,4	7,1	8,1	9,2	10,3	11,5	l/s
	Pressure drops plant side	47	38	40	41	44	42	45	46	48	48	49	kPa
	Water flow rate source side	4,0	4,5	5,3	6,1	6,8	7,7	8,6	9,8	11,1	12,5	13,9	l/s
	Pressure drops source side	68	55	59	60	65	62	66	67	70	71	72	kPa
IW		70.2	80.2	90.2	105.2	120.2	135.2	150.2	170.2	190.2	215.2	240.2	
W30W7	Cooling capacity	69,5	78,5	91,4	104,3	117,2	132,1	146,9	168,8	190,5	214,3	238,1	kW
	Power input	16,4	18,1	21,9	25,2	28,6	32,3	36,3	41,3	46,4	53,0	59,7	kW
	EER	4,23	4,34	4,17	4,14	4,10	4,09	4,05	4,09	4,11	4,04	3,99	-
	ESEER	5,22	5,26	5,07	5,04	5,02	5,03	5,05	5,03	5,07	5,03	5,04	-
	Water flow rate plant side	3,34	3,77	4,40	5,02	5,64	6,35	7,07	8,12	9,17	10,32	11,47	l/s
	Pressure drops plant side	47	38	40	41	44	42	45	46	48	48	49	kPa
	Water flow rate source side	4,03	4,54	5,32	6,07	6,83	7,71	8,58	9,84	11,09	12,52	13,94	l/s
	Pressure drops source side	68	55	59	60	65	62	66	67	70	71	72	kPa
W10W45	Heating capacity	78,7	87,6	103,8	117,9	132,1	149,2	166,5	190,7	215,0	242,3	270,6	kW
	Power input	20,6	22,5	27,1	30,9	34,8	39,2	44,1	50,2	56,5	63,8	71,4	kW
	COP	3,81	3,90	3,84	3,82	3,80	3,81	3,78	3,80	3,81	3,80	3,79	-
	Water flow rate plant side	3,73	4,16	4,92	5,59	6,26	7,07	7,88	9,03	10,18	11,47	12,80	l/s
	Pressure drops plant side	58	46	50	51	54	52	56	57	59	59	61	kPa
	Water flow rate source side	4,03	4,54	5,32	6,07	6,83	7,71	8,58	9,84	11,09	12,52	13,94	l/s
Pressure drops source side	68	55	59	60	65	62	66	67	70	71	72	kPa	
IP		70.2	80.2	90.2	105.2	120.2	135.2	150.2	170.2	190.2	215.2	240.2	
W30W7	Cooling capacity	68,1	77,0	89,6	102,3	114,9	129,5	144,0	165,4	186,8	210,1	233,4	kW
	Power input	16,2	17,9	21,6	24,9	28,2	31,8	35,8	40,7	45,7	52,3	58,9	kW
	EER	4,20	4,31	4,14	4,11	4,07	4,07	4,03	4,07	4,09	4,02	3,96	-
	ESEER	5,16	5,20	5,02	5,01	5,00	5,01	5,02	5,00	5,02	5,00	5,01	-
	Water flow rate plant side	3,3	3,7	4,3	4,9	5,5	6,2	6,9	8,0	9,0	10,1	11,2	l/s
	Pressure drops plant side	45	36	38	39	42	40	43	44	46	46	47	kPa
	Water flow rate source side	3,95	4,45	5,22	5,96	6,71	7,57	8,43	9,66	10,89	12,29	13,69	l/s
	Pressure drops source side	66	53	56	58	62	60	64	65	68	68	70	kPa
W10W45	Heating capacity	77,7	86,6	102,8	116,8	130,8	147,7	165,4	188,8	212,8	239,8	267,9	kW
	Power input	20,7	22,5	27,1	31,0	34,9	39,3	44,2	50,3	56,4	64,0	71,6	kW
	COP	3,76	3,85	3,80	3,77	3,75	3,76	3,74	3,76	3,77	3,75	3,74	-
	Water flow rate plant side	3,7	4,1	4,9	5,5	6,2	7,0	7,8	8,9	10,1	11,4	12,7	l/s
	Pressure drops plant side	57	45	49	50	53	51	55	56	58	58	60	kPa
	Water flow rate source side	3,95	4,45	5,22	5,96	6,71	7,57	8,43	9,66	10,89	12,29	13,69	l/s
Pressure drops source side	66	53	56	58	62	60	64	65	68	68	70	kPa	

Data declared according to EN 14511. The values are referred to units without options and accessories.

EER (Energy Efficiency Ratio) = ratio of the total cooling capacity to the effective power input of the unit

COP (Coefficient Of Performance) = ratio of the total heating capacity to the effective power input of the unit

ESEER (European Seasonal Energy Efficiency Ratio) = Unit in **A CLASS**.

W30W7 = source : water in 30°C out 35°C / plant : water in 12°C out 7°C

W10W45 = source : water in 10°C / plant : water in 40°C out 45°C

NET NOMINAL performances - Radiant plants

IR		70.2	80.2	90.2	105.2	120.2	135.2	150.2	170.2	190.2	215.2	240.2	
W30W7	Cooling capacity	94,0	105,2	121,2	140,0	158,7	178,4	197,6	227,0	257,2	288,8	321,4	kW
	Power input	18,8	20,3	24,5	28,4	32,6	36,6	41,3	47,1	53,2	60,7	68,6	kW
	EER	5,01	5,19	4,95	4,94	4,86	4,88	4,79	4,82	4,83	4,76	4,69	-
	Water flow rate plant side	4,55	5,08	5,86	6,77	7,68	8,63	9,56	10,99	12,46	13,99	15,58	l/s
	Pressure drops plant side	87	69	71	75	82	78	82	84	89	88	90	kPa
	Water flow rate source side	5,25	5,87	6,80	7,86	8,92	10,03	11,13	12,77	14,45	16,27	18,14	l/s
	Pressure drops source side	116	92	96	101	110	105	111	114	119	119	123	kPa
IW		70.2	80.2	90.2	105.2	120.2	135.2	150.2	170.2	190.2	215.2	240.2	
W30W7	Cooling capacity	94,0	105,2	121,2	140,0	158,7	178,4	197,6	227,0	257,2	288,8	321,4	kW
	Power input	18,8	20,3	24,5	28,4	32,6	36,6	41,3	47,1	53,2	60,7	68,6	kW
	EER	5,01	5,19	4,95	4,94	4,86	4,88	4,79	4,82	4,83	4,76	4,69	-
	Water flow rate plant side	4,55	5,08	5,86	6,77	7,68	8,63	9,56	10,99	12,46	13,99	15,58	l/s
	Pressure drops plant side	87	69	71	75	82	78	82	84	89	88	90	kPa
	Water flow rate source side	5,25	5,87	6,80	7,86	8,92	10,03	11,13	12,77	14,45	16,27	18,14	l/s
	Pressure drops source side	116	92	96	101	110	105	111	114	119	119	123	kPa
W10W45	Heating capacity	85,2	95,8	112,3	128,3	144,5	162,9	181,5	208,1	234,8	264,9	295,2	kW
	Power input	17,9	19,4	23,5	27,2	31,0	34,9	39,3	44,9	50,6	57,8	65,3	kW
	COP	4,75	4,93	4,78	4,73	4,65	4,67	4,61	4,64	4,64	4,58	4,52	-
	Water flow rate plant side	4,03	4,54	5,32	6,07	6,83	7,71	8,58	9,84	11,09	12,52	13,94	l/s
	Pressure drops plant side	68	55	59	60	65	62	66	67	70	71	72	kPa
	Water flow rate source side	5,25	5,87	6,80	7,86	8,92	10,03	11,13	12,77	14,45	16,27	18,14	l/s
	Pressure drops source side	116	92	96	101	110	105	111	114	119	119	123	kPa
IP		70.2	80.2	90.2	105.2	120.2	135.2	150.2	170.2	190.2	215.2	240.2	
W30W7	Cooling capacity	90,8	101,0	117,0	135,0	153,0	172,0	190,6	218,6	247,5	278,4	309,5	kW
	Power input	19,0	20,1	24,1	28,1	32,3	36,1	41,0	46,7	52,5	59,5	66,6	kW
	EER	4,79	5,01	4,85	4,80	4,74	4,77	4,65	4,69	4,72	4,68	4,65	-
	Water flow rate plant side	4,40	4,87	5,65	6,52	7,40	8,31	9,22	10,58	11,98	13,48	14,99	l/s
	Pressure drops plant side	81	63	66	69	76	72	77	78	82	82	84	kPa
	Water flow rate source side	5,12	5,67	6,60	7,62	8,64	9,72	10,81	12,37	13,98	15,75	17,52	l/s
	Pressure drops source side	110	86	90	95	103	98	105	107	111	112	114	kPa
W10W45	Heating capacity	83,7	94,0	110,3	126,1	142,1	159,5	178,2	204,6	230,3	260,3	289,5	kW
	Power input	17,6	19,0	23,1	26,7	30,4	34,2	38,6	43,9	49,5	56,6	63,9	kW
	COP	4,74	4,95	4,78	4,73	4,68	4,67	4,62	4,66	4,65	4,60	4,53	-
	Water flow rate plant side	3,96	4,45	5,22	5,97	6,72	7,55	8,43	9,68	10,88	12,30	13,68	l/s
	Pressure drops plant side	66	53	56	58	63	59	64	65	68	68	70	kPa
	Water flow rate source side	5,12	5,67	6,60	7,62	8,64	9,72	10,81	12,37	13,98	15,75	17,52	l/s
	Pressure drops source side	110	86	90	95	103	98	105	107	111	112	114	kPa

Data declared according to **EN 14511**. The values are referred to units without options and accessories.

EER (Energy Efficiency Ratio) = ratio of the total cooling capacity to the effective power input of the unit

COP (Coefficient Of Performance) = ratio of the total heating capacity to the effective power input of the unit

ESEER (European Seasonal Energy Efficiency Ratio)

= Unit in **A CLASS**.

W30W7 = source : water in 30°C out 35°C / plant : water in 12°C out 7°C

W10W45 = source : water in 10°C / plant : water in 40°C out 45°C

Acoustic performances

Base setting up (AB)	70.2	80.2	90.2	105.2	120.2	135.2	150.2	170.2	190.2	215.2	240.2	
Sound power level ^(E)	75	76	77	77	77	78	78	79	79	80	80	dB(A)
Sound pressure level at 1 meter	59	60	61	61	61	62	62	63	63	64	64	dB(A)
Sound pressure level at 5 meters	49	50	51	51	51	52	52	53	53	54	54	dB(A)
Sound pressure level at 10 meters	44	45	46	46	46	47	47	48	48	49	49	dB(A)
Low noise setting up (AS)	70.2	80.2	90.2	105.2	120.2	135.2	150.2	170.2	190.2	215.2	240.2	
Sound power level ^(E)	71	72	73	73	73	74	74	75	75	76	76	dB(A)
Sound pressure level at 1 meter	55	56	57	57	57	58	58	59	59	60	60	dB(A)
Sound pressure level at 5 meters	45	46	47	47	47	48	48	49	49	50	50	dB(A)
Sound pressure level at 10 meters	40	41	42	42	42	43	43	44	44	45	45	dB(A)
eXtra low noise setting up (AX)	70.2	80.2	90.2	105.2	120.2	135.2	150.2	170.2	190.2	215.2	240.2	
Sound power level ^(E)	67	68	69	69	69	70	70	71	71	72	72	dB(A)
Sound pressure level at 1 meter	51	52	53	53	53	54	54	55	55	56	56	dB(A)
Sound pressure level at 5 meters	41	42	43	43	43	44	44	45	45	46	46	dB(A)
Sound pressure level at 10 meters	36	37	38	38	38	39	39	40	40	41	41	dB(A)

(E): EUROVENT certified data

The acoustic performances are referred to units operating in cooling mode at nominal conditions W30/W7.

Unit placed in free field on reflecting surface (directional factor equal to 2).

The sound power level is measured according to ISO 9614 standard.

The sound pressure level is calculated according to ISO 3744 and is referred to a distance of 1/5/10 metres from the external surface of the unit.

Technical data

Unit	70.2	80.2	90.2	105.2	120.2	135.2	150.2	170.2	190.2	215.2	240.2	
Power supply	400 - 3 - 50											V-ph-Hz
Compressor type	scroll											-
N° compressors / N° refrigerant circuits	2 / 1											n°
Plant side heat exchanger type	stainless steel brazed plates											-
Source side heat exchanger type	stainless steel brazed plates											-
IN/OUT Plant side hydraulic fittings	2" 1/2 VICTAULIC											"
IN/OUT Source side hydraulic fittings	2" 1/2 VICTAULIC											"

Electrical data

Standard unit	70.2	80.2	90.2	105.2	120.2	135.2	150.2	170.2	190.2	215.2	240.2	
FLA - Full load current at maximum tolerated conditions	45	51	62	68	74	82	90	105	120	142	164	A
FLI - Full load power input at maximum tolerated conditions	26	29	34	40	45	50	55	63	72	83	93	kW
MIC - Maximum instantaneous current of the unit	141	166	204	256	262	309	317	355	370	454	476	A
MIC SS - Maximum instantaneous current of the unit with soft starter options	93	110	135	166	172	200	208	231	246	296	318	A
Unit with high head modulating pump	70.2	80.2	90.2	105.2	120.2	135.2	150.2	170.2	190.2	215.2	240.2	
FLA - Full load current at maximum tolerated conditions	60	66	77	83	89	103	111	129	144	169	191	A
FLI - Full load power input at maximum tolerated conditions	35	38	42	48	54	62	67	77	86	98	109	kW
MIC - Maximum instantaneous current of the unit	155	180	219	271	277	330	338	379	394	481	503	A
MIC SS - Maximum instantaneous current of the unit with soft starter options	108	124	149	181	187	221	229	255	270	323	345	A

Operating range

Temperature	Unit type	Cooling		Heating		
		min	max	min	max	
Water inlet temperature source side	IR, IW, IP, BR, BP	20 (5*)	50	10	25 (40*)	(°C)
Water outlet temperature plant side	IR, IW, IP	5	20	25	55	(°C)
Water outlet temperature plant side	BR, BP	-10	5	25	55	(°C)

* with condensation / evaporation control devices

CONTROL SYSTEM

The units are equipped with a controller designed to ensure energy saving and unit efficiency. Available functions :

- Adaptive function
- Climatic control in heating and in cooling mode
- Economy function
- Demand limit
- Integrative heating
- Condensation / evaporation control
- Remote stand by
- Remote cooling-heating



DIMENSIONS - MINIMUM OPERATING AREA - WEIGHT

(reference drawing: unit with closing panel)

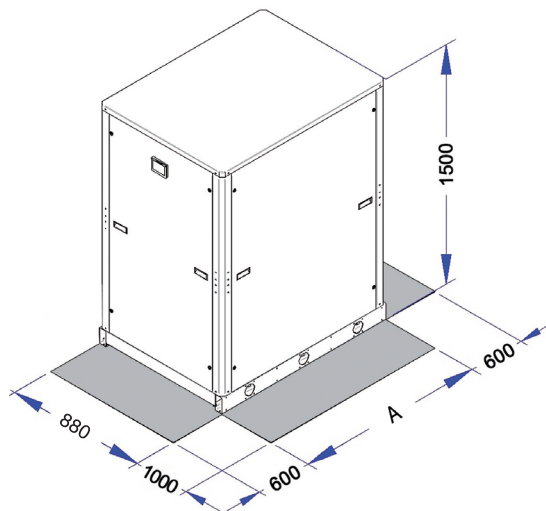

		70.2	80.2	90.2	105.2	120.2	135.2	150.2	170.2	190.2	215.2	240.2	
STANDARD UNIT	A	880											mm
	Operating maximum weight	404	416	427	548	635	668	696	741	771	812	844	kg
STANDARD UNIT+ PUMPING MODULE MP	A	2055					2350						mm
	Operating maximum weight (2+2 extra high head pumps)	809	817	828	1059	1146	1225	1253	1321	1351	1415	1447	kg